

Operating Instructions

Color Video Monitor

Model No. **BT-S901YN**

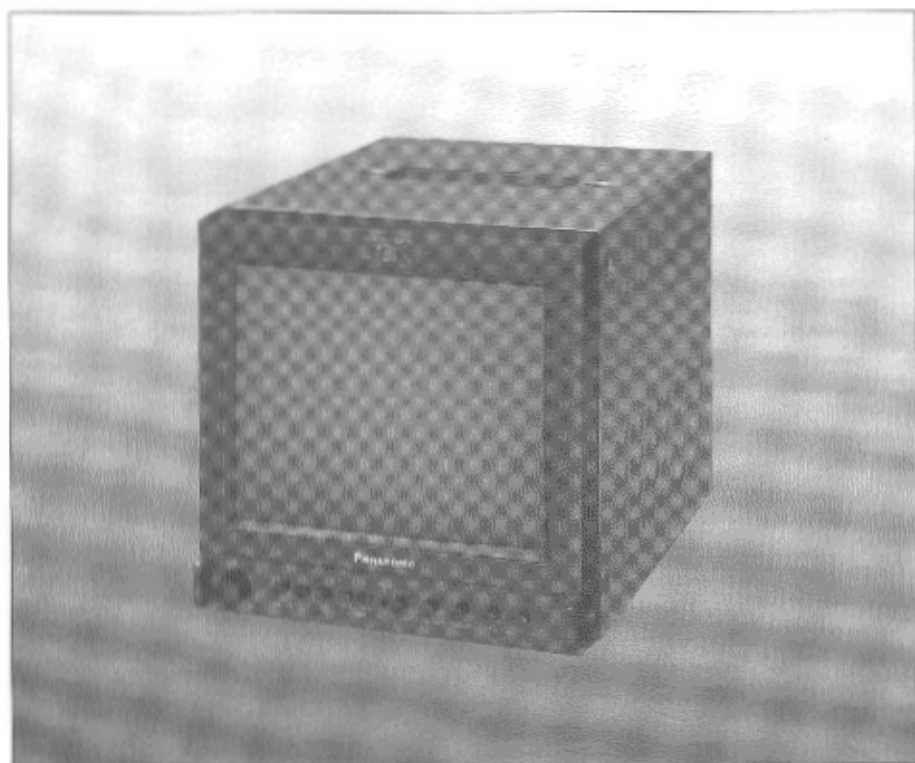

Panasonic®

Please read these instructions completely, before operating this set.

TQBJ0020

Dear Panasonic Customer;

Welcome to our Panasonic family of customers. It is our desire that you have many years of enjoyment from your new Color Video Monitor.

Customer's Record

The serial number of this product may be found on its back cover. You should note the serial number of this unit in the space provided and retain this book as a permanent record of your purchase to aid in identification in the event of theft or loss.

Model number: BT-S901YN

Serial number: _____

Note: This Color Video Monitor is designed to operate in the U.S.A., and in other countries where the broadcasting system and AC power are exactly the same as those in the U.S.A.

WARNING: To reduce the risk of fire or electric shock, do not expose this appliance to rain or moisture.

The following cautions are attached to this color video monitor:

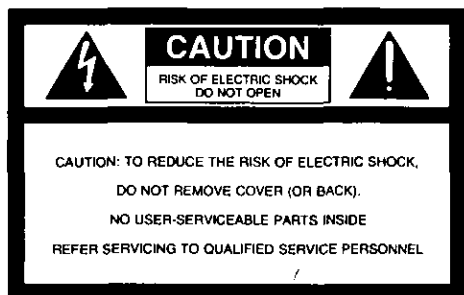

The lightning flash with arrowhead within a triangle is intended to tell the user that parts inside the product present a risk of electric shock to persons.



The exclamation point within a triangle is intended to tell the user that important operating and servicing instructions are contained in the paper work accompanying the video monitor.

WARNING: This equipment has been tested and found to comply with the limits for a Class A digital device, pursuant to Part 15 of the FCC Rules. These limits are designed to provide reasonable protection against harmful interference when the equipment is operated in a commercial environment. This equipment generates, uses, and can radiate radio frequency energy and, if not installed and used in accordance with the instruction manual, may cause harmful interference to radio communications. Operation of this equipment in a residential area is likely to cause harmful interference in which case the user will be required to correct the interference at his own expense.

CAUTION: Any unauthorized changes or modifications to this equipment would void the users authority to operate.

Table of Contents

Precautions	2
Features	3
Control Locations	4
Operations	5
Video/Audio Terminals	6
Connections	8
Specifications	8

Precautions

- ❶ Do not attempt to disassemble the Color Video Monitor.
To prevent electric shock, do not remove screws or cover. There are no user-serviceable parts inside. Refer servicing to qualified service personnel.
- ❷ Location
Adequate ventilation is essential to prevent failure of the electrical components.
Avoid direct sunlight on the set. Do not mount above heat generating equipment or near high magnetic fields.
- ❸ Do not use this Color Video Monitor beyond its temperature and humidity range.
 - (a) This unit is designed for indoor use. Ambient temperature must not exceed the range of 32°F ~ 104°F (0°C ~ +40°C).
 - (b) Avoid using this Color Video Monitor when the humidity is either above 80% or less than 20%.
 - (c) Do not block the ventilation slits on the bottom, sides and rear panels. If rack mounted, allow ventilation space or force cool the unit.
- ❹ The input power source is 120V 50Hz/60Hz AC.
- ❺ Do not remove the grounding pin on the AC power plug.
This Color Video Monitor is equipped with a three wire grounding-type power plug. This plug will only fit a grounding-type power outlet.
This is a safety feature. If you are unable to insert the plug into the outlet, contact an electrician. Do not defeat the purpose of the grounding plug.

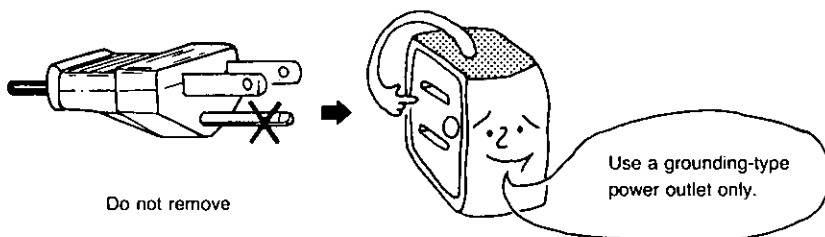

Features

- ❶ Two selectable input signals (LINE A / LINE B)
- ❷ Applicable of both Video and S-Video signals (Switch selectable at LINE A)
- ❸ NTSC-M System (American TV Standard 525 Line/60 Field)
- ❹ Underscan (Switch Selectable)
- ❺ Pulse Cross (Switch Selectable)
- ❻ BLUE Only for monitor set up and balance with the SMPTE color bar signal.(Switch Selectable)
- ❼ INT/EXT Sync (Switch Selectable)
- ❽ Automatic Impedance Change for Video and Sync In/Out terminals (75ohm or high)
- ❾ A compact designed attractive metal cabinet
- ❿ Capable of rack-mounting with optional brackets
- ⓫ Virtually no magnetic/electrical interference

❿ Controls

- Front:
 - POWER/VOL Control
 - Underscan Switch
 - BLUE Only Switch
 - V-HOLD Control
 - BRIGHT Control
 - COLOR Control
 - LINE A / LINE B Change Switch
 - Pulse Cross Switch
 - INT/EXT SYNC Switch
 - CONTRAST Control
 - TINT Control
- Rear: Impedance Change Switch (75 Ω or HI-Z, S-VIDEO)
VIDEO/S-VIDEO Switch (LINE A only)
- Behind Access Panel:
 - Aperture Control (Front)

⓬ Input/Output

- LINE A
 - S-VIDEO IN/OUT : 4P MINI DIN Type
 - VIDEO IN/OUT : BNC Type
 - AUDIO IN/OUT : RCA Phono Type
- LINE B
 - VIDEO IN/OUT : BNC Type
 - AUDIO IN/OUT : RCA Phono Type
- EXTERNAL SYNC IN/OUT : BNC Type

Control Locations

FRONT

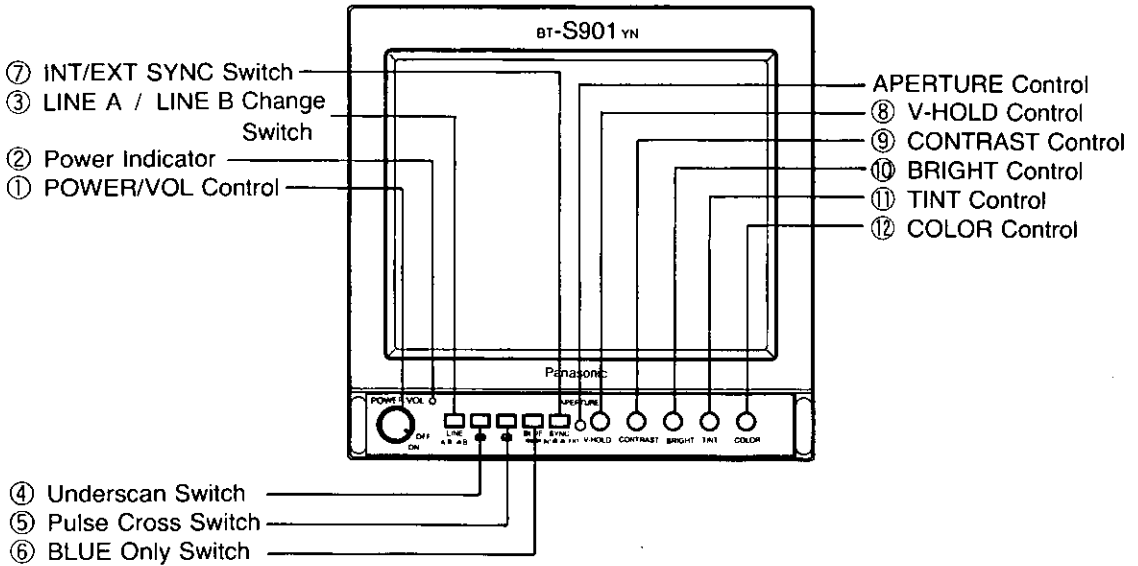

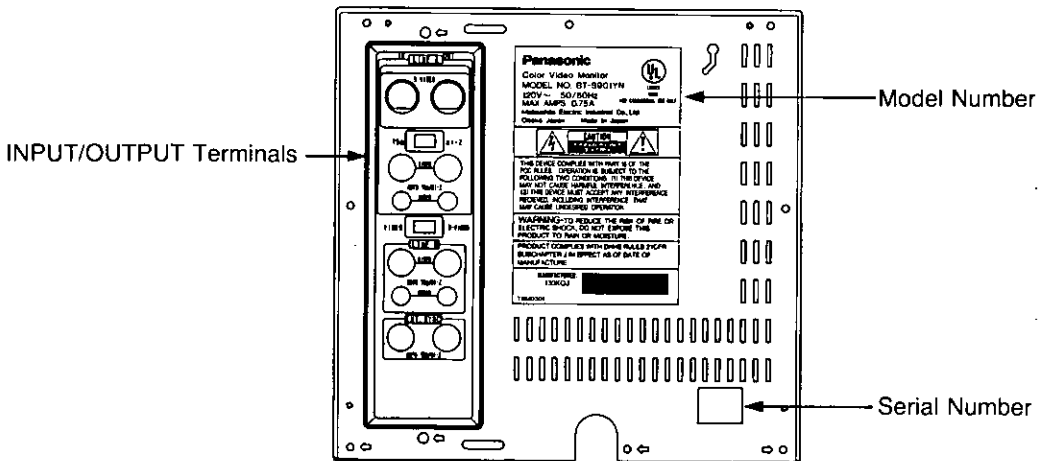

REAR



- Note:** 1. The circled numbers indicate the control description item on the following page.
2. The APERTURE control is not user adjustable and should only be adjusted by a qualified service personnel.

Operations

<p>① POWER/VOL Control</p>	<p>1. Turn clockwise to turn the monitor on. Turn counterclockwise to turn the monitor off.</p> <p>2. Adjust this control for the appropriate audio level.</p>
<p>② Power Indicator</p>	<p>The Power Indicator will light when the monitor is turned on.</p>
<p>③ LINE A / LINE B Change Switch</p> <p>A  B</p>	<p>LINE A: Receives video signal from the VIDEO IN terminal or S-VIDEO signal from the S-VIDEO IN terminal, and audio signal from AUDIO IN terminal.</p> <p>LINE B: Receives video and audio signals from the VIDEO IN and AUDIO IN terminals.</p>
<p>④ Underscan Switch ()</p>	<p>Decreases the overall picture size to allow the corners to be seen.</p>
<p>⑤ Pulse Cross Switch ()</p>	<p>Receives cross pulse to allow vertical and horizontal syncs to be seen in the picture.</p>
<p>⑥ BLUE Only Switch (<u>BLUE</u>)</p>	<p>Defeats the red and green signals. This feature is used for monitor balancing with the SMPTE color bar signal.</p>
<p>⑦ INT/EXT SYNC Switch</p>	<p>Set the INT/EXT SYNC Switch to EXT Position when connecting an external composite sync signal to the monitor.</p>
<p>⑧ V-HOLD Control</p>	<p>Adjust the V-Hold control if the picture rolls up or down.</p>
<p>⑨ CONTRAST Control</p>	<p>Adjust the contrast level for proper overall contrast. There is a click position for normal level.</p>
<p>⑩ BRIGHT Control</p>	<p>Adjust the brightness level for proper overall picture brightness. There is a click position for normal level.</p>
<p>⑪ TINT Control</p>	<p>Adjust the Tint control for proper chroma phase of flesh tones.</p>
<p>⑫ COLOR Control</p>	<p>Adjust the Color control to set the chroma (saturation) level.</p>

Video/Audio Terminals

Terminal Board on Rear Cover

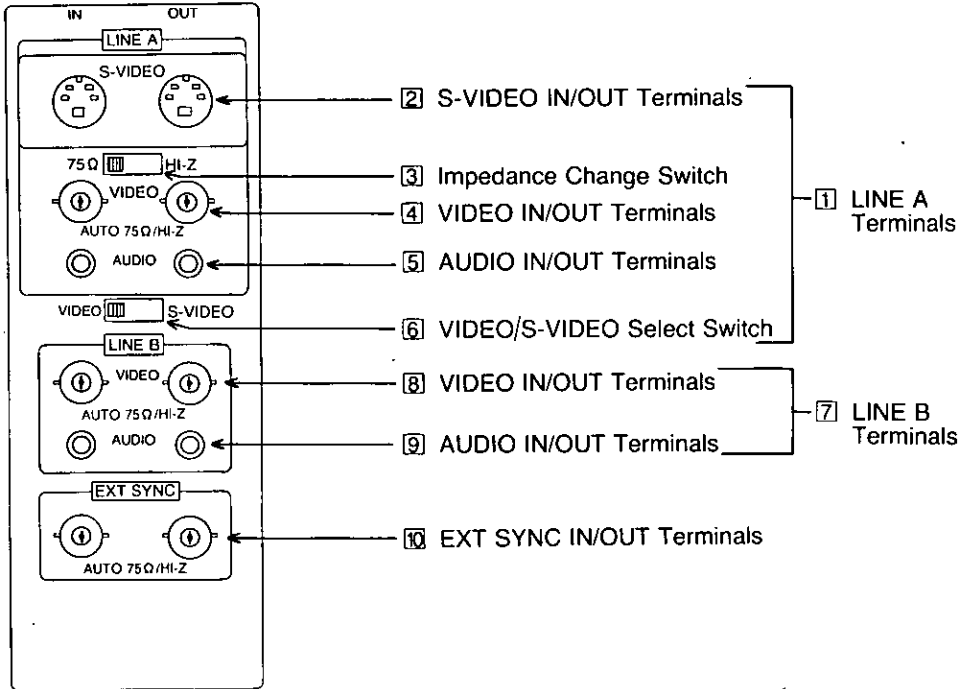

Signal Level and Terminal Impedance

Terminal	Item	Level	Impedance	Remarks
S-VIDEO	INPUT	Y: 1Vp-p C: 0.3Vp-p	75 Ω or High (Switchable)	
	OUTPUT	Y: 1Vp-p C: 0.3Vp-p	75 Ω or High (Switchable)	
VIDEO	INPUT	1Vp-p (0.7Vp-p)	Auto 75 Ω/High	Includes sync signal. (Does not include sync signal.)
	OUTPUT	1Vp-p (0.7Vp-p)	Auto 75 Ω/High	
AUDIO	INPUT	-6dB	10 kΩ	1 Vrms = 0 dB at 400Hz
	OUTPUT	-6dB	10 kΩ	
EXT. SYNC	INPUT	2~4Vp-p	Auto 75 Ω/High	Negative vertical and horizontal sync
	OUTPUT	2~4Vp-p	Auto 75 Ω/High	

① LINE A Terminals	Available when LINE A / LINE B Change Switch on the front panel is set to "LINE A".
② S-VIDEO IN/OUT Terminals	Connect S-VIDEO signal to IN terminal. The same signal is available at the OUT terminal.
③ Impedance Change Switch	Set this switch to 75 Ω for the S-VIDEO termination or to HI-Z for bridge-connection to next unit.
④ VIDEO IN/OUT Terminals	Connect video signal to IN terminal. The same signal is available at the OUT terminal.
⑤ AUDIO IN/OUT Terminals	Connect audio signal to IN terminal. The same signal is available at the OUT terminal.
⑥ VIDEO/S-VIDEO Select Switch	When the video signal is applied, set this switch to VIDEO position and when the S-VIDEO signal is applied, set this switch to S-VIDEO position.
⑦ LINE B Terminals	Available when LINE A / LINE B Change Switch on the front panel is set to "LINE B".
⑧ VIDEO IN/OUT Terminals	Connect video signal to IN terminal. The same signal is available at the OUT terminal.
⑨ AUDIO IN/OUT Terminals	Connect audio signal to IN terminal. The same signal is available at the OUT terminal.
⑩ EXT SYNC IN/OUT Terminals	Connect an external composite sync signal to this terminal when a non-composite video signal is applied to the video terminals (④ or ⑧).

Note: 1. The video and the external sync input/output terminals are equipped with "Automatic Termination Switch". If only input signal is applied, they are terminated by 75ohm, and if both input/output signals applied, they are opened to high impedance.

2. It is possible to connect up to 10 monitors in series by looping through the S-VIDEO IN and S-VIDEO OUT or the VIDEO IN and VIDEO OUT terminals. There may be a possibility of a brightness reduction or interference if more than 10 units are connected. Please carefully confirm that these problems do not exist with the units before connection.

Connections

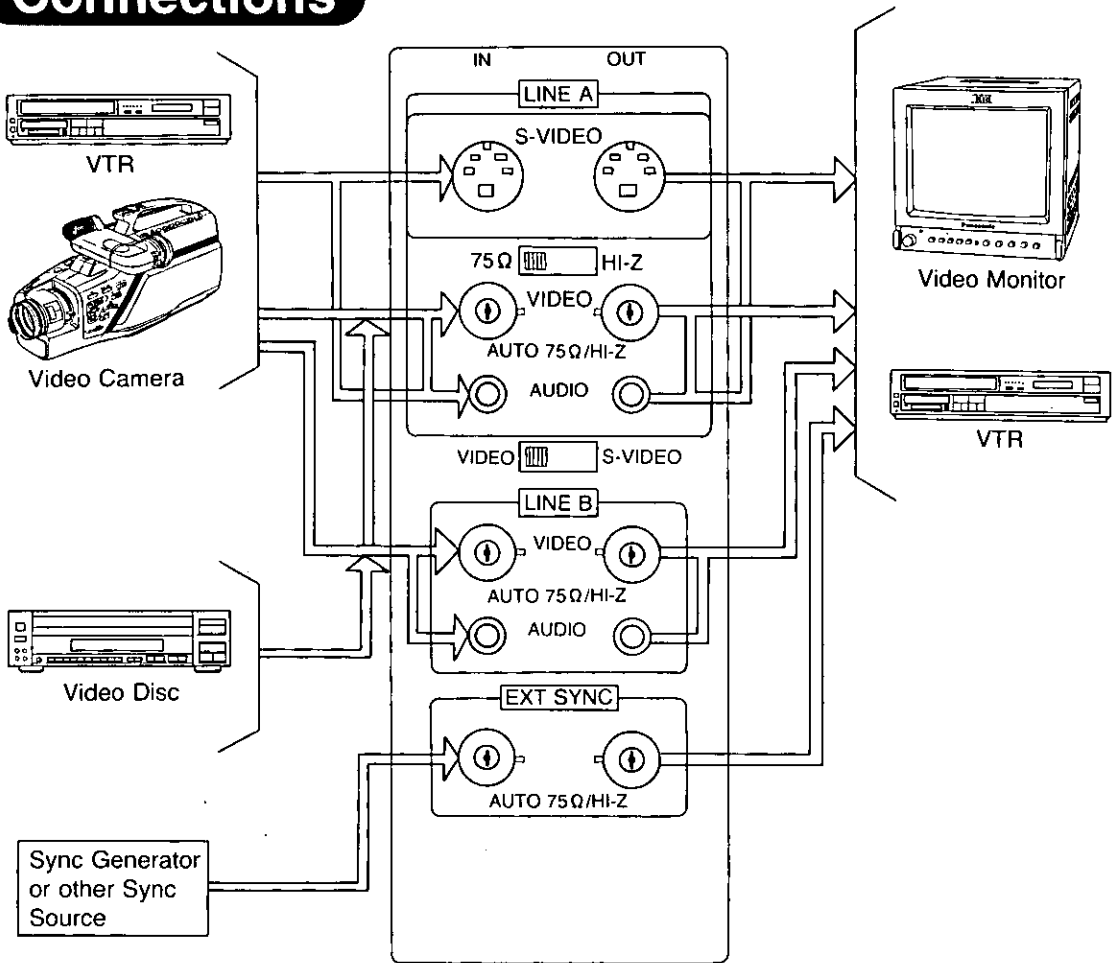

Specifications

Power Source:	120V 50/60Hz AC
Power Consumption:	37 W
Television System:	NTSC-M System (American TV Standard 525 Line/60 Field)
Dimensions (W X D X H):	8 ²⁵ / ₃₂ " X 12 ¹¹ / ₁₆ " X 9" (223 mm) X (321.5 mm) X (228.5 mm)
Weight:	15.5 lbs. (7.0 kg)
Picture Tube:	9 inches, 90° deflection
Speaker:	2 1/2 inch round type, located on cabinet left
Speaker Output Level:	1.0W (at 10% distortion)
Operation Temperature Range:	32°F ~ 104°F (0°C ~ +40°C)
Operation Humidity Range:	20% ~ 80%
Option:	Rack Kit (TY-LK100)

Contents subject to change without notice.

Panasonic®

Professional/Industrial Video

Panasonic Broadcast & Television Systems Company

Division of Matsushita Electric Corporation of America

Executive Office:

One Panasonic Way (2E-6) Secaucus, New Jersey 07094

EASTERN ZONE:

One Panasonic Way (4E-7) Secaucus, New Jersey 07094 (201) 348-7620

CENTRAL ZONE:

1707 N. Randall Road (E1C-1) Elgin, IL 60123 (847) 468-5210

SOUTHERN ZONE:

Atlanta Region: 1225 Northbrook Parkway, Suite 160 (Panazip#11) Suwanee, GA (770) 338-6823

WESTERN ZONE:

Los Angeles Region: 6550 Katella Ave., Cypress, CA 90630 (714) 373-7878

Government Marketing Department: 52 West Gude Drive, Rockville, MD 20850 (301) 738-3840

Matsushita Electric Corporation of America

Corporate Sales Group, Hawaii Region

99-859 Iwaiwa St., Aiea, HI 96701-3267 (808) 488-7779

Panasonic Sales Company

Division of Matsushita Electric of Puerto Rico, Inc.

San Gabriel Industrial Park, 65th Infantry Ave., K.M. 9.5, Carolina, PR 00630 (809) 750-4300
